

## CFA-SWM

### Specifications

Powered by:	Tuya App	Compatible:	Google Home <sup>®</sup> & Amazon Alexa <sup>®</sup>
-------------	----------	-------------	--

*Note: Designed to work with Domus Ceiling Fans.*

## Installing the Smart WIFI Module

Remove the insert on your fan receiver and install the Smart WIFI Module.

### No Light Fan Receiver

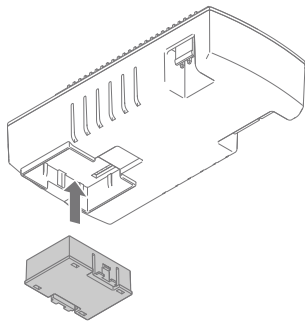

### With Light Fan Receiver

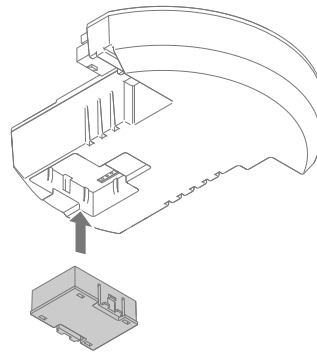

## Set up the Smart WIFI Module Tuya Smart App

Before setting up the Smart WIFI Module with the Tuya Smart App, make sure you have the following:

- A Smart WIFI Module installed in your ceiling fan receiver and power to your fan
- A WIFI router with active internet connection
- The wireless network name (SSID) and password of your router.
- Download the free Tuya Smart App by searching for Tuya Smart in your App store or by scanning the following QR code.

### Get Started

1. Open the Tuya Smart App and follow the instructions on the App to register/sign up & log in.
2. Follow the prompts using a choice of either mobile phone number or email address.
3. Turn on WIFI on your mobile phone and ensure fan is in the same WIFI area.
4. Open your Tuya Smart App and choose "add device". Device should be automatically and choose "add".
5. Select a 2.4GHz WIFI network and enter password. If your WIFI is 5GHz, it should also display a 2.4GHz version as a WIFI option available, please set to the 2.4GHz option. Select "Next".
6. The device should be successfully added. To rename the device, click the "Pencil" button.

**Note:** -Must be installed by professional electrician  
-Ensure the power supply is switched off before fitting this product

NOTE: If the setup fails, please reset the device to original setting and start again. To reset your fan if the set up has failed. Turn off your fan and turn on again with isolation switch and use the handpiece to do the programming by press and hold F/R button then the Smart WIFI module is back to factory setting. When the reset is successful, the receiver will beep 2 times and if a light is fitted to the ceiling fan, it will flash twice. For further instructions for how to install the Smart WIFI Module, please scan the QR code.

### Maximise Product Life and Protect your Warranty

Damage caused by voltage or current surges will shorten the life of the product and is not covered by warranty. Surges may be caused by lightning, problems in the electricity network or out of specification voltages from solar inverters. The chance of damage can be minimised by turning off the isolation switch when fan is not being used. It is good practice to turn off the iso-lation switch just like you would with a normal light switch.

### Warranty Terms and Conditions:

This statement is required by the Australian Consumer Law 2010: "Our goods come with guarantees that cannot be excluded under the Australian Consumer Law. You are entitled to a replacement or refund for a major failure and for compensation for any other reasonably foreseeable loss or damage. You are also entitled to have the goods repaired or replaced if the goods fail to be of acceptable quality and the failure does not amount to a major failure."

Domus Lighting will cover, for a period of 24 months (Residential) or 12 months (Commercial) from date of purchase, replacement of the defective Domus Ceiling Fan Module.